

REMOVAL – 3.0L DIESEL

1. Disconnect the negative battery cable.
2. Remove engine cover.

3. Disconnect the EGR valve harness connector (1).

WARNING: Do not remove the coolant hoses or open the cooling system when it is hot and under pressure. Serious burns from coolant can occur.

4. Disconnect the coolant hoses (2) from the EGR valve.

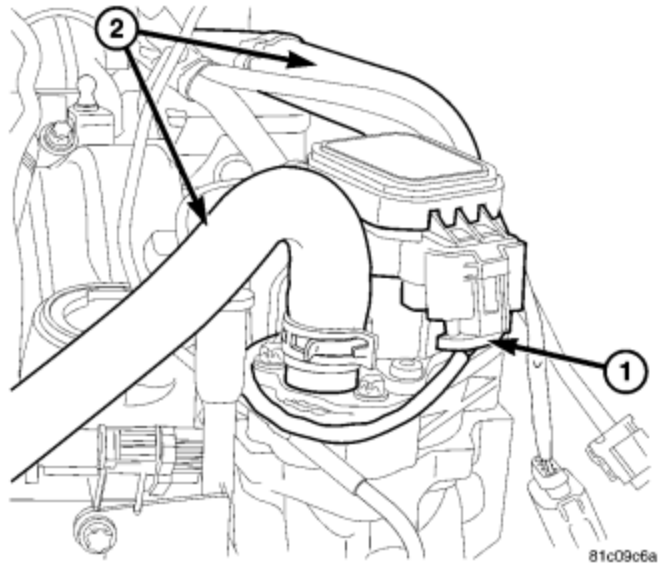

5. Remove the rear EGR valve retaining bolts (1).

6. Remove the front EGR valve retaining bolts (1) and valve (2), discard the gasket.

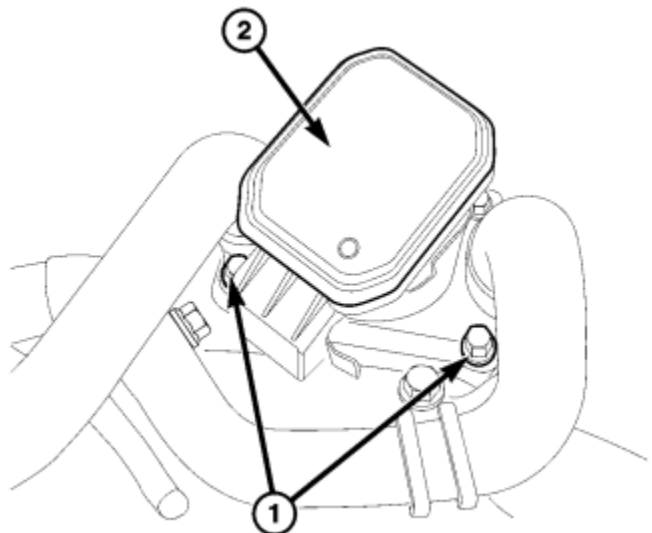
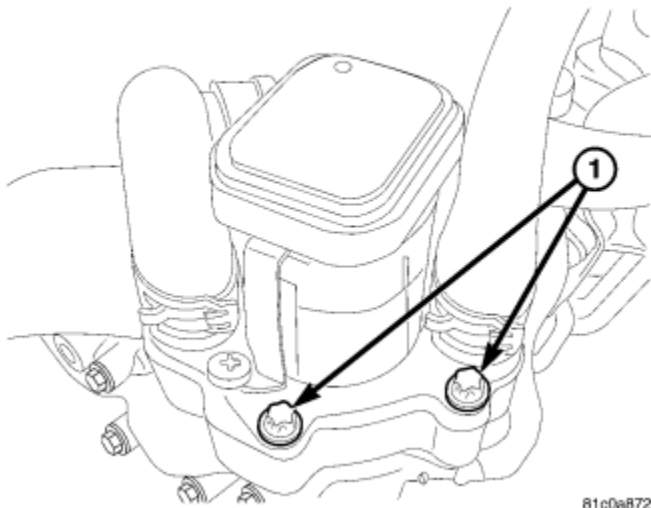

INSTALLATION – 3.0L DIESEL

1. Clean EGR valve sealing surfaces and install a new gasket.

2. Install the EGR valve (2), and install the front EGR valve retaining bolts (1).

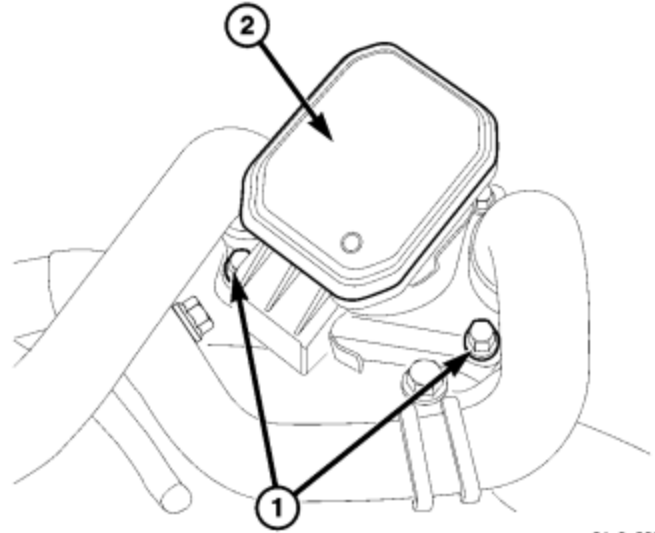

81c0a866

3. Install the rear EGR valve retaining bolts (1).

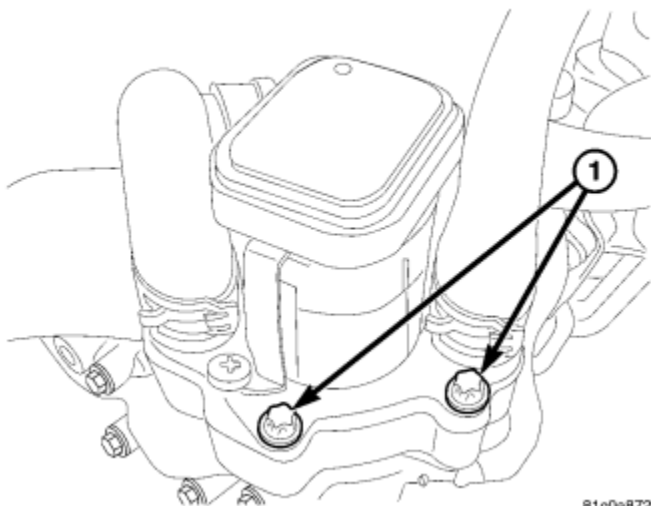

4. Reconnect the coolant hoses (2).

5. Reconnect the EGR valve harness connector (1).

6. Install engine cover.

7. Connect the negative battery cable.

81c0a872

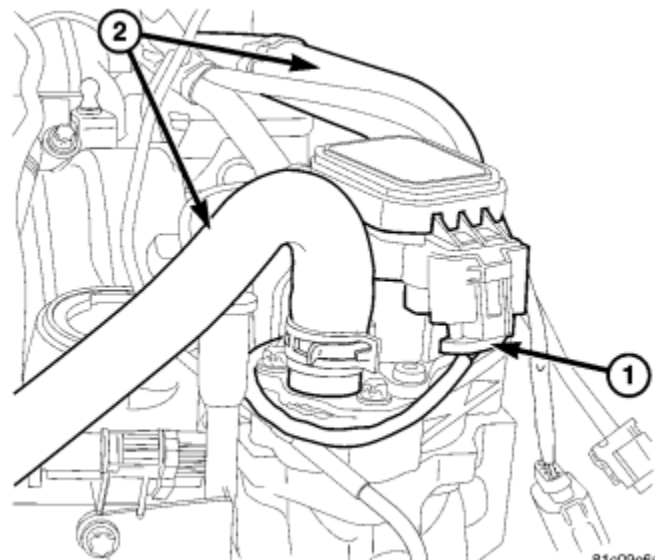

81c09c6a