

# North American NCV3 Wheel Alignment Information

## DESCRIPTION

**NOTE:** Caster is not adjustable on this vehicle. (CAMBER AND TOE ONLY).

**NOTE:** A cam/bolt kit is available to achieve more camber if needed, This kit must be installed in place of the existing lower strut bolts.

**NOTE:** Suspension components with rubber/urethane bushings should be tightened with the vehicle at normal ride height. It is important to have the springs supporting the weight of the vehicle when the fasteners are torqued. If springs are not at their normal ride position, vehicle ride comfort could be affected and premature bushing wear may occur.

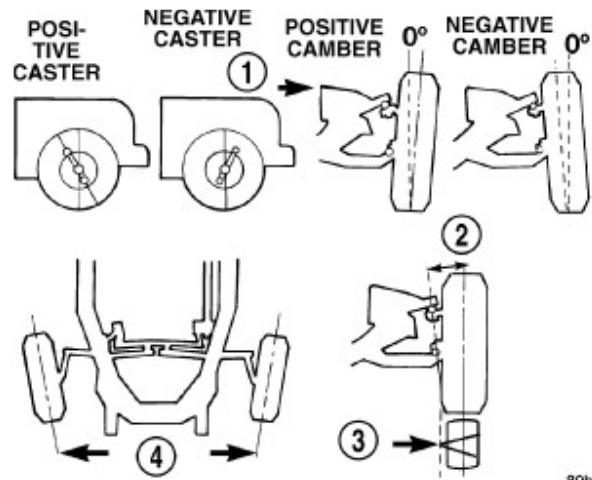

80b0d70b

Wheel alignment involves the correct positioning of the wheels in relation to the vehicle. The positioning is accomplished through suspension and steering linkage adjustments. An alignment is considered essential for efficient steering, good directional stability and to minimize tire wear. The most important measurements of an alignment are caster, camber and toe.

**CAUTION:** Never attempt to modify suspension or steering components by heating or bending.

# PRE-ALIGNMENT INSPECTION

Before starting wheel alignment, the following inspection and necessary corrections must be completed. Refer to Suspension and Steering System Diagnosis Chart below for additional information.

1. Inspect tires for size, air pressure and tread wear.
2. Inspect front wheel bearings for wear.
3. Inspect front wheels for excessive radial or lateral runout and balance.
4. Inspect ball studs, linkage pivot points and steering gear for looseness, roughness or binding.
5. Inspect suspension components for wear and noise.
6. Road test the vehicle.

## SUSPENSION AND STEERING SYSTEM DIAGNOSIS

CONDITION	POSSIBLE CAUSES	CORRECTION
FRONT END NOISE	<ol style="list-style-type: none"><li>1. Loose or worn wheel bearing.</li><li>2. Loose or worn steering or suspension components.</li><li>3. Loose or worn steering or suspension components.</li></ol>	<ol style="list-style-type: none"><li>1. Replace knuckle.</li><li>2. Tighten or replace components as necessary.</li><li>3. Tighten or replace components as necessary.</li></ol>
EXCESSIVE PLAY IN STEERING	<ol style="list-style-type: none"><li>1. Loose or worn wheel bearing.</li><li>2. Loose or worn steering or suspension components.</li><li>3. Loose or worn steering gear.</li></ol>	<ol style="list-style-type: none"><li>1. Replace knuckle.</li><li>2. Tighten or replace components as necessary.</li><li>3. Replace steering gear.</li></ol>
FRONT WHEELS SHIMMY	<ol style="list-style-type: none"><li>1. Loose or worn wheel bearing.</li><li>2. Loose or worn steering or</li></ol>	<ol style="list-style-type: none"><li>1. Replace knuckle.</li><li>2. Tighten or replace components</li></ol>

CONDITION	POSSIBLE CAUSES	CORRECTION
	suspension components.  3. Tires worn or out of balance.  4. Alignment.	as necessary.  3. Replace or balance tires.  4. Align vehicle to specifications.
VEHICLE INSTABILITY	1. Loose or worn wheel bearing.  2. Loose or worn steering or suspension components.  3. Tire pressure.  4. Alignment.	1. Replace knuckle.  2. Tighten or replace components as necessary.  3. Adjust tire pressure.  4. Align vehicle to specifications.
EXCESSIVE STEERING EFFORT	1. Loose or worn steering gear.  2. Column coupler binding.  3. Tire pressure.  4. Alignment.	1. Replace steering gear.  2. Replace coupler.  3. Adjust tire pressure.  4. Align vehicle to specifications.
VEHICLE PULLS TO ONE SIDE	1. Tire pressure.  2. Tire.  3. Alignment.  4. Loose or worn steering or suspension components.  5. Radial tire lead.  6. Brake pull.	1. Adjust tire pressure.  2. Criss-Cross Front Tires.  3. Align vehicle to specifications.  4. Tighten or replace components as necessary.  5. Rotate or replace tire as necessary.  6. Repair brake as necessary.

CONDITION	POSSIBLE CAUSES	CORRECTION
	7. Weak or broken spring.	7. Replace spring.

# CAMBER ADJUSTMENT

1. Raise the vehicle on an alignment hoist.

**NOTE:** Before each alignment check, measure the distance between the wheel center (2) and wheel well housing (1) on either side of the vehicle. Verify that it is between minimum and maximum values given. If so, the alignment check can be performed. If not, adjust the height of the front of the vehicle as necessary using the cradle until the distance is within specification. ([Refer to 02 - Front Suspension/Wheel Alignment - Specifications](#)).

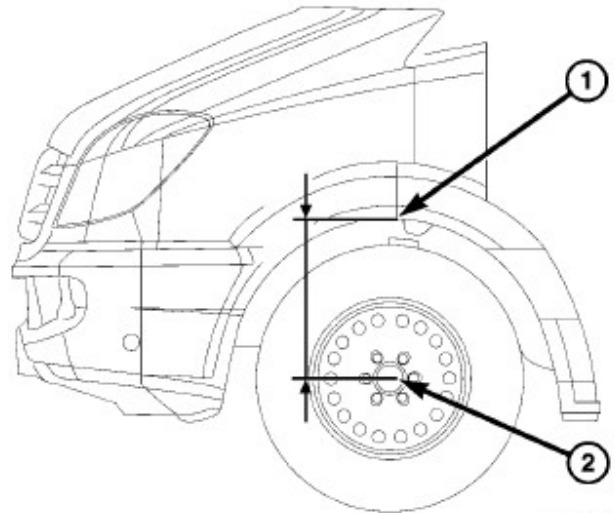

81c4dfda

Before each alignment reading the vehicle should be jounced (rear first, then front). Grasp each bumper at the center and jounce the vehicle up and down several times. Always release the bumper in the down position. Also curb height should be checked prior to an alignment. **Set the front end alignment to specifications while the vehicle is in its NORMALLY LOADED CONDITION AND CORRECT CURB HEIGHT.**

Camber angle adjustments involve changing the position of the knuckle at the strut base ([Refer to 02 - Front Suspension/Wheel Alignment - Specifications](#)).

**NOTE:** A cam/bolt kit is available to achieve more camber if needed, This kit must be installed in place of the existing lower strut bolts.

2. Loosen the lower strut bolts (2) to allow the knuckle to move inward or outward for camber adjustment.

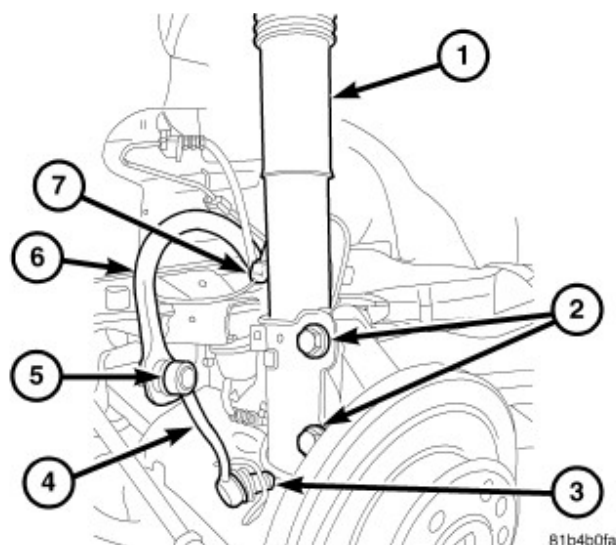

81b4b0fa

The wheel toe position adjustment is the final adjustment.

3. Start the engine and turn wheels both ways before straightening the wheels. Secure the steering wheel with the front wheels in the straight-ahead position.
4. Loosen the tie rod jam nuts (2).

**NOTE:** Each front wheel should be adjusted for one-half of the total toe position specification. This will ensure the steering wheel will be centered when the wheels are positioned straight-ahead.

5. Adjust the wheel toe position by turning the inner tie rod (1) as necessary.
6. Tighten the tie rod jam nut (2) to 50 N-m (37 ft. lbs.).
7. Verify the specifications
8. Turn off engine.

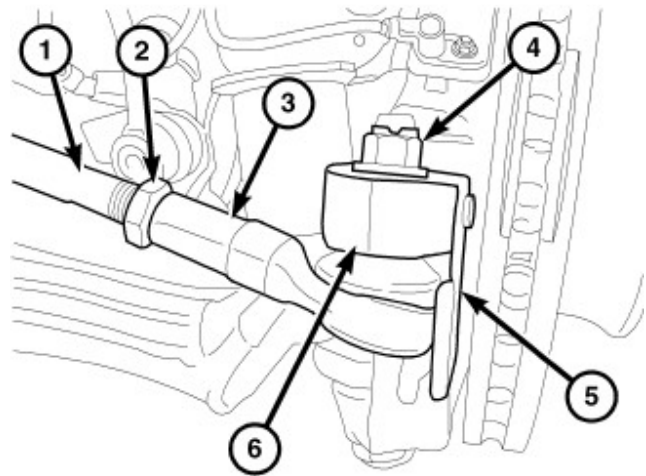

81b4b51a

# TOE ADJUSTMENT

The wheel toe position adjustment is the final adjustment.

1. Start the engine and turn wheels both ways before straightening the wheels. Secure the steering wheel with the front wheels in the straight-ahead position.
2. Loosen the tie rod jam nuts (2).

**NOTE:** Each front wheel should be adjusted for one-half of the total toe position specification. This will ensure the steering wheel will be centered when the wheels are positioned straight-ahead.

3. Adjust the wheel toe position by turning the inner tie rod (1) as necessary.
4. Tighten the tie rod jam nut (2) to 50 N·m (37 ft. lbs.).
5. Verify the specifications
6. Turn off engine.

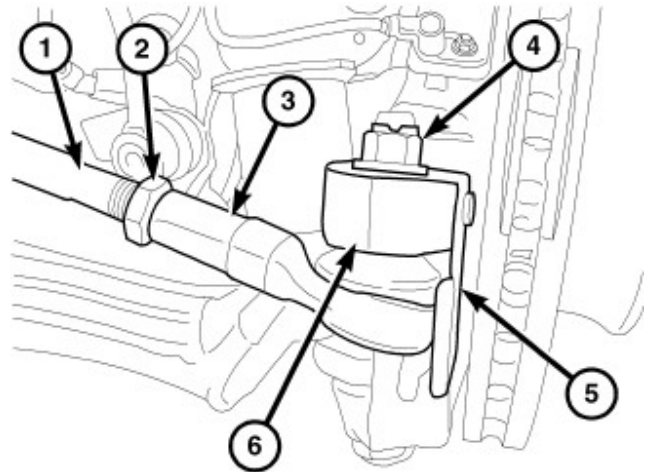

81b4b51a

# WHEEL ALIGNMENT, CURB HEIGHT, AND TORQUE SPECIFICATIONS

## WHEEL ALIGNMENT

**NOTE:** Before each alignment check the front and rear curb heights of the vehicle. Verify that it is between minimum and maximum values given.

2500 AND 3500 SERIES WITHOUT reinforced front axle	
Toe-In	0.2°(±0.1°)
Camber	1.0°(±0.3°)
Caster	See Curb Height Chart for proper Caster specification per vehicle

3500 SERIES WITH reinforced front axle	
Toe-In	0.25°(±0.1°)
Camber	1.3°(±0.3°)
Caster	See Curb Height Chart for proper Caster specification per vehicle

## FRONT AND REAR CURB HEIGHT SPECIFICATIONS

**NOTE:** Before each alignment check, measure the distance between the wheel center (2) and wheel well housing (1) on either side of the vehicle. Verify that it is between minimum and maximum values given. (This is the requirement for toe-in, camber and caster). Adjusting the rear curb height is not necessary when measuring it and choosing a spec from the table accordingly.

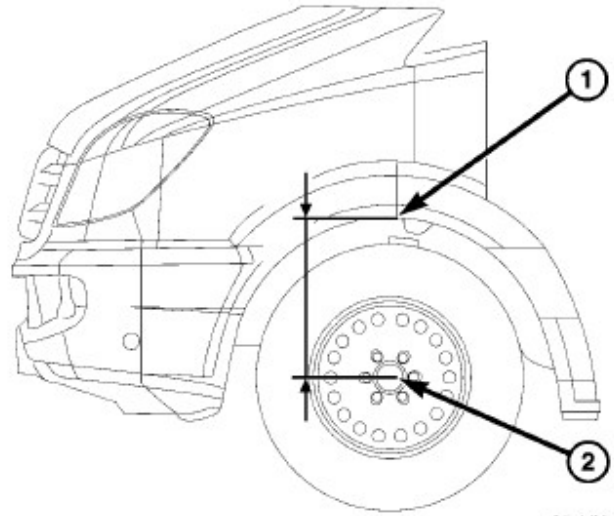

81c4dfda

To check front curb height measure the distance between the wheel center (2) and the wheel well housing (1) which should be between the given specifications.

To check Rear curb height measure the distance between the rear shock upper bolt (1) head to the lower bolt head (2).

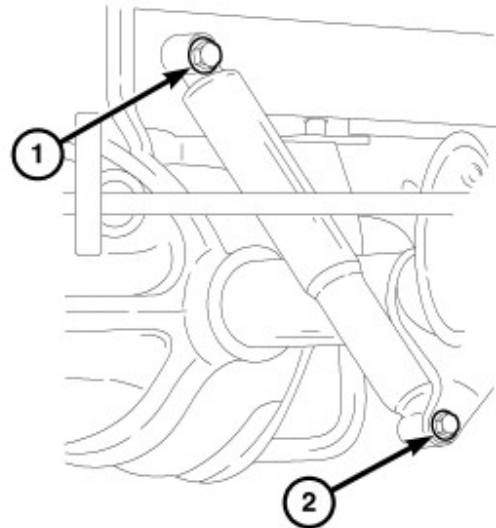

81dbd41c

**2500 SERIES AND 3500 SERIES without reinforced axle. Mid Wheel Base Vehicle (3665 mm (144 in.))**

FRONT CURB HEIGHT	REAR CURB HEIGHT	CASTER
467 mm (18.4 in.) Minimum	509 mm (20 in.)	2.6°(±0.5°)
502 mm (19.8 in.) Maximum	501 mm (19.7 in.)	2.8°(±0.5°)
	492 mm (19.3 in.)	2.9°(±0.5°)
	484 mm (19 in.)	3.1°(±0.5°)
	476 mm (18.7 in.)	3.2°(±0.5°)
	467 mm (18.3 in.)	3.4°(±0.5°)
	460 mm (18.1 in.)	3.6°(±0.5°)
	451 mm (17.7 in.)	3.7°(±0.5°)
	442 mm (17.4 in.)	3.9°(±0.5°)
	434 mm (17 in.)	4.0°(±0.5°)
	426 mm (16.7 in.)	4.2°(±0.5°)
	417 mm (16.4 in.)	4.3°(±0.5°)
	409 mm (16.1 in.)	4.5°(±0.5°)
	400 mm (15.7 in.)	4.7°(±0.5°)
	392 mm (15.4 in.)	4.8°(±0.5°)

3500 SERIES with reinforced axle. Mid Wheel Base Vehicle (3665 mm (144 in.))		
FRONT CURB HEIGHT	REAR CURB HEIGHT	CASTER
497 mm (19.6 in.) Minimum	509 mm (20 in.)	2.7°(±0.5°)
513 mm (20.2 in.) Maximum	501 mm (19.7 in.)	2.9°(±0.5°)
	492 mm (19.3 in.)	3.0°(±0.5°)
	484 mm (19 in.)	3.2°(±0.5°)
	476 mm (18.7 in.)	3.3°(±0.5°)
	467 mm (18.3 in.)	3.5°(±0.5°)
	460 mm (18.1 in.)	3.7°(±0.5°)
	451 mm (17.7 in.)	3.8°(±0.5°)
	442 mm (17.4 in.)	4.0°(±0.5°)
	434 mm (17 in.)	4.1°(±0.5°)
	426 mm (16.7 in.)	4.3°(±0.5°)
	417 mm (16.4 in.)	4.4°(±0.5°)
	409 mm (16.1 in.)	4.6°(±0.5°)
	400 mm (15.7 in.)	4.7°(±0.5°)
	392 mm (15.4 in.)	4.9°(±0.5°)

**2500 SERIES AND 3500 SERIES without reinforced axle. Long Wheel Base Vehicle (4325 mm (170 in.))**

FRONT CURB HEIGHT	REAR CURB HEIGHT	CASTER
467 mm (18.4 in.) Minimum	509 mm (20 in.)	2.9°(±0.5°)
502 mm (19.8 in.) Maximum	501 mm (19.7 in.)	3.1°(±0.5°)
	492 mm (19.3 in.)	3.2°(±0.5°)
	484 mm (19 in.)	3.3°(±0.5°)
	476 mm (18.7 in.)	3.5°(±0.5°)
	467 mm (18.3 in.)	3.6°(±0.5°)
	460 mm (18.1 in.)	3.7°(±0.5°)
	451 mm (17.7 in.)	3.9°(±0.5°)
	442 mm (17.4 in.)	4.0°(±0.5°)
	434 mm (17 in.)	4.1°(±0.5°)
	426 mm (16.7 in.)	4.3°(±0.5°)
	417 mm (16.4 in.)	4.4°(±0.5°)
	409 mm (16.1 in.)	4.5°(±0.5°)
	400 mm (15.7 in.)	4.7°(±0.5°)
	392 mm (15.4 in.)	4.8°(±0.5°)

**3500 SERIES with reinforced axle. Long Wheel Base Vehicle (4325 mm (170 in.))**

FRONT CURB HEIGHT	REAR CURB HEIGHT	CASTER
497 mm (19.6 in.) Minimum	509 mm (20 in.)	3.0°(±0.5°)
513 mm (20.2 in.) Maximum	501 mm (19.7 in.)	3.1°(±0.5°)
	492 mm (19.3 in.)	3.3°(±0.5°)
	484 mm (19 in.)	3.4°(±0.5°)
	476 mm (18.7 in.)	3.5°(±0.5°)
	467 mm (18.3 in.)	3.7°(±0.5°)
	460 mm (18.1 in.)	3.8°(±0.5°)
	451 mm (17.7 in.)	3.9°(±0.5°)
	442 mm (17.4 in.)	4.1°(±0.5°)
	434 mm (17 in.)	4.2°(±0.5°)
	426 mm (16.7 in.)	4.3°(±0.5°)
	417 mm (16.4 in.)	4.5°(±0.5°)
	409 mm (16.1 in.)	4.6°(±0.5°)
	400 mm (15.7 in.)	4.7°(±0.5°)
	392 mm (15.4 in.)	4.9°(±0.5°)

## TORQUE

DESCRIPTION	N·m	Ft. Lbs.	In. Lbs.
Outer Tie Rod End Jam Nut	50	37	–